

WTRO - II - 4 STAGE FILTRATION

MAKES UP TO 25 GALLONS PER DAY!

Stage 1

Sediment Cartridge removes sand, silt, rust and scale.

Stage 2

Carbon Cartridge removes volatile organic chemical contaminants.

Stage 3

Thin film composite reverse osmosis membrane removes inorganic contaminants, metal and salts - to 1800 TDS.

Stage 4

Post carbon G.A.C cartridge polishes purified water.



Universal Filters

Replacement filters are readily available from us and other sources.

Thin Film Composite

Reverse Osmosis Membrane effective to 1800 ppm. TDS. Fast recovery - 25 Gal. / Day!

Proven Reliability and Durability

THOUSANDS in service in western United States.

Automatic Shut Off

Conserves water by automatically shutting down when storage tank is full.

Chrome Faucet

Sink mounted, dual action faucet included. (Designer colors are available)

Pre-tested and Inspected

All of our units before leaving, are inspected to be free of leaks and defects before installation.

High Flow Plumbing

3/8" tubing for fast flow from storage tank.

Locally Manufactured by Water Tec of Tucson Inc.

From only the highest quality components at our facility in TUCSON, ARIZONA.

Over 40 Year Reputation

Of immaculate customer service satisfaction, integrity and quality!

Why settle for anything but the best?

	<p>WATER TEC OF TUCSON 4601 S. 3RD AVE. TUCSON, AZ 85714 PHONE (520)790-1512 FAX (520)745-0549</p> <p>WATER TEC OF PHOENIX PHONE (602)288-1422 FAX (520)745-0549</p> <p>WATER TEC OF NEVADA PHONE (702)270-0900 FAX (702)270-4350</p> <p>WEBSITE: www.water-tec.com E-MAIL: questions@water-tec.com AZ ROC# 098794 / 104403 NV ROC# 0055223</p>
---	---

Providing service after the sale since 1967.

BENEFITS OF QUALITY R.O. WATER

- * Clean, fresh drinking water - 25 Gallons per day
- * Better tasting coffee, tea and mixed beverages
- * Clean and harder ice cubes - line from R.O can also be connected to ice makers
- * More flavorful foods prepared with purified water
- * Plants and pets thrive on quality water
- * Steam irons, humidifiers, car batteries, etc. last longer.

Reverse Osmosis is the process in which tap water is forced through a semi permeable membrane, leaving unwanted substance behind. These substances are rinsed away, resulting in fresh and clean drinking water. **The Water Tec II is a four stage drinking water processor utilizing fibrous sediment filters, high grade Granular Activated Carbon filters, Thin Film Composite R.O membrane and storage tank.**

OUR SERVICE TECHNICIANS CAN DELIVER AND ADD SALT OR POTASSIUM TO YOUR SYSTEM ON A SCHEDULED ROUTE !

Material	% Rejection	Material	% Rejection
Sodium	90-93%	Lead	96-98%
Calcium	94-97%	Chloride	87-93%
Magnesium	96-98%	Bicarbonate	90-95%
Potassium	87-94%	Nitrate	60-75%
Iron	95-98%	Fluoride	87-89%
Manganese	95-98%	Silicate	85-90%
Aluminum	98-99%	Phosphate	98-99%
Ammonium	98-99%	Chromate	86-92%
Copper	98-99%	Cyanide	86-92%
Nickel	98-99%	Sulfite	96-98%
Zinc	98-99%	Thiosulfate	96-99%
Strontium	98-99%	Ferro cyanide	98-99%
Cadmium	96-98%	Bromide	87-93%
Silver	93-98%	Borate	30-50%
Mercury	96-98%	Sulfate	98-99%
Barium	96-98%	Arsenic	94-96%
Chromium	96-99%	Selenium	94-96%

Removes over 90% of Sodium from Tap Water

* Ideal for low sodium diets *

Also removes

- * Benzene
- * EDB
- * Trichloroethane
- * TCE
- * DBCP
- * THM's
- * Dichloropropane
- * Dichloroethylene

System Options and Up-Grades

- * Hook up line to refrigerator - automatic ice maker
- * Designer color faucets, styles and finishes available.
- * 50/75/100 Gallon per day Thin Film Composite R.O Membrane
- * Higher capacity pressurized water storage tanks

1. Polishing Filter
2. Capillary
3. Membrane & Housing
4. Pre-filter
5. Post-filter
6. Shut off Valve
7. Ball Valve
8. Tank

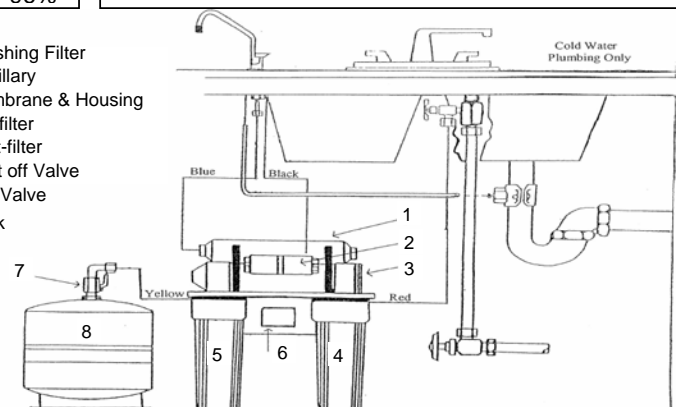

Providing service after the sale since 1967.